

# Unit Air Separator

## Models

Available in a range of sizes designed for throughputs of between 5kgs and 100 tonnes per hour.

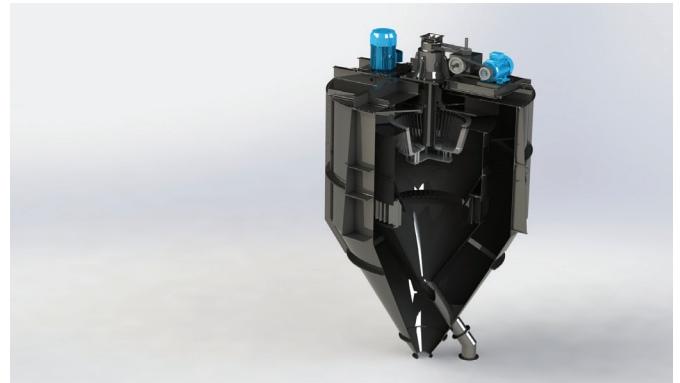
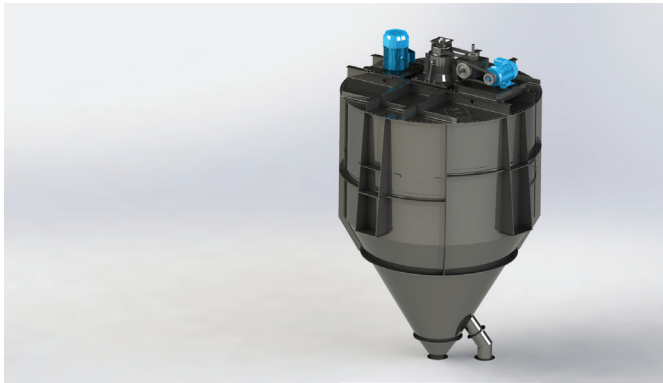

## Applications

The Unit Air Separator with its twin drive system is suitable for the classification of a wide range of materials and is the most economic unit available in terms of kWhr/tonne of product. In addition to its capabilities as a high-performance classifier providing products in the range of 25 to 300 microns, it is particularly suitable for the removal of small quantities of oversize material or the de-dusting of granular materials to remove undesirable 'fines'.

Whilst effective as a self-contained stand-alone machine, with its own integral fan and without the need for an additional filter, separator or fan, the Unit Air Separator can also be operated in closed circuit with a variety of grinding mills.

## Options

Abrasion-resistant linings available.

## Features and benefits

- Operating range from 25 to 300 microns
- Twin drive system – airflow can be controlled independently of the classifier speed
- Cut-point easily changed without stopping or opening the machine
- Low operating speed
- Low power consumption
- Unit construction inhibits dust emission
- Easy access for inspection and cleaning
- Rapid changeover from one product specification to another
- Requires no external fan or product collection system
- Independent drives for internal fan and internal classifier
- Robust construction and build quality for long service life

## Unit Air Separator operating principles

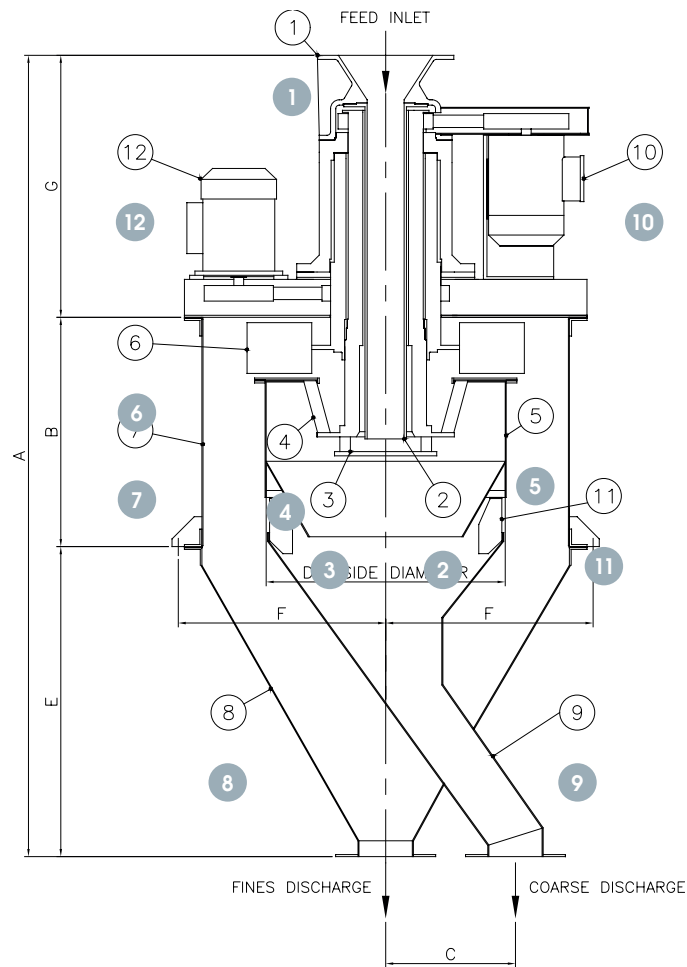

Feed material enters the machine through the hopper **(1)** and descends through the stationary feed tube **(2)**.

The dispersing rotor **(3)** then distributes the material into the circulating airstream created by the fan **(6)**.

The speed of the fan can be varied through the drive motor **(12)** to adjust the air velocity.

Airborne material is then conveyed by the circulating airstream to the classification rotor **(4)** where the classification takes place.

The particles are classified as a result of the interaction between the centripetal and air drag forces within the vortex generated by the rotor.

Coarse material migrates to the walls of the inner cylinder **(5)** and descends down the coarse discharge chute **(9)**.

Fine material passes through the classification rotor **(4)** and fan **(6)** to be collected in the outer cylinder **(7)** by cyclonic action and descends down the fines discharge chute **(8)**.

The cut-point is adjusted by varying the classifying rotor speed through the rotor drive motor **(10)**.

Air is re-circulated to the classification rotor through the return vanes **(11)**.

## Unit Air Separator equipment range technical data

UNIT AIR SEPARATOR MODEL		75TD	100TD	150TD	200TD	250TD	300TD	375TD	425TD	500TD
APPROX. FEED RATE (TONNES/HR)	FROM	0.3	0.5	1.1	2.0	3.0	4.5	7.0	9.0	12.5
	TO	1.4	2.5	5.5	10.0	15.0	22.0	35.0	45.0	62.0
MOTOR POWER (kW)	FROM	2.0	4.0	7.5	11.0	18.5	22.0	27.0	45.0	55.0
	TO	2.0	4.0	7.5	15.0	22.0	30.0	45.0	55.0	75.0

All dimensions in mm

<b>A</b>	1,708	2,283	3,242	3,950	4,833	5,632	6,756	7,530	8,650
<b>B</b>	493	652	977	1,303	1,628	1,950	2,441	2,762	3,250
<b>C</b>	305	370	490	670	800	980	1,200	1,400	1,570
<b>D</b>	750	1,000	1,500	2,000	2,500	3,000	3,750	4,250	5,000
<b>E</b>	663	882	1,382	1,803	2,111	2,535	3,168	3,588	4,220
<b>F</b>	470	595	860	1,150	1,450	1,700	2,100	2,350	2,800
<b>G</b>	552	749	883	872	1,094	1,147	1,147	1,180	1,180
<b>APPROX. NET WEIGHT (KG)</b>	630	998	1,960	3,080	6,300	9,100	15,120	21,000	29,800

**Note:** All data provided is for guidance only and may be varied at any time by the company.

British Rema Process Equipment Ltd  
Image Works, Foxwood Close  
Chesterfield, Derbyshire S41 9RB  
United Kingdom

+44 (0)1246 269 955  
equipmentknowhow@britishrema.com  
britishrema.com

Registered in England No. 05556424 | VAT No. 872 0080 45